



06/2012 -

DACIA LODGY

Cat. No. G/007

e20

e20*94/20*0899*00

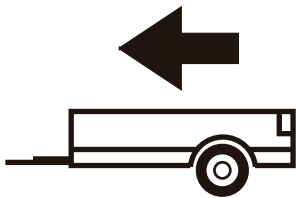

1450Kg

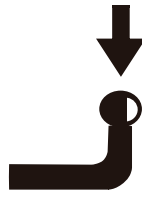

75Kg

D = 8,10kN

D (kN) =



MAX kg

x

MAX kg

x 0,00981



MAX kg

+

MAX kg

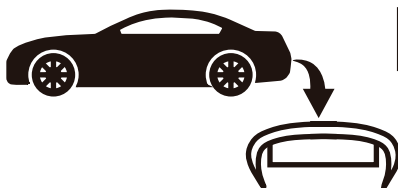

IMIOLA HAK-POL

96-111 KOWIESY, CHOJNATA 23A, POLAND

tel. +48 46 831 73 31, fax +48 831 74 29

e-mail: office@imiola.pl, www.imiola.pl

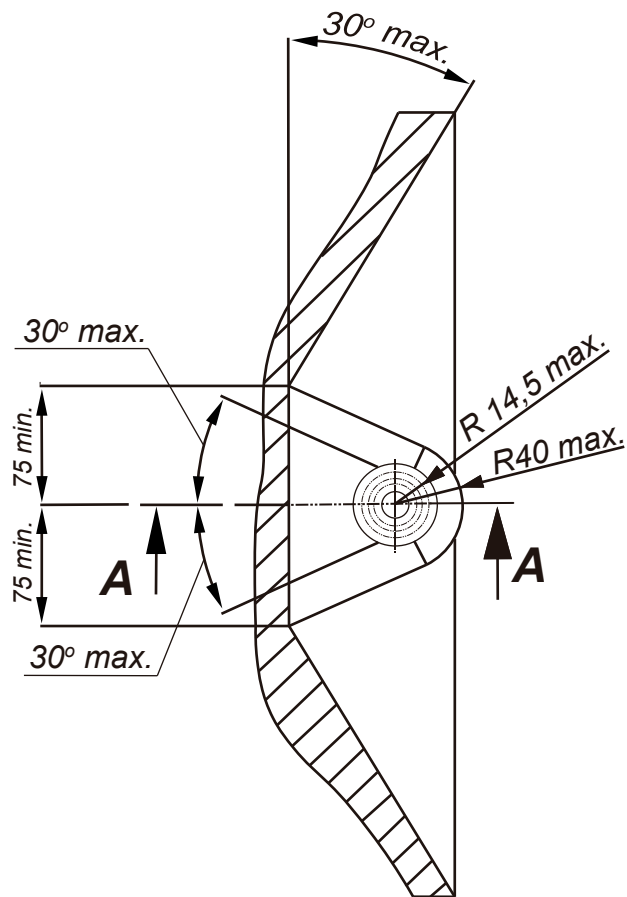

PRZEKRÓJ A-A

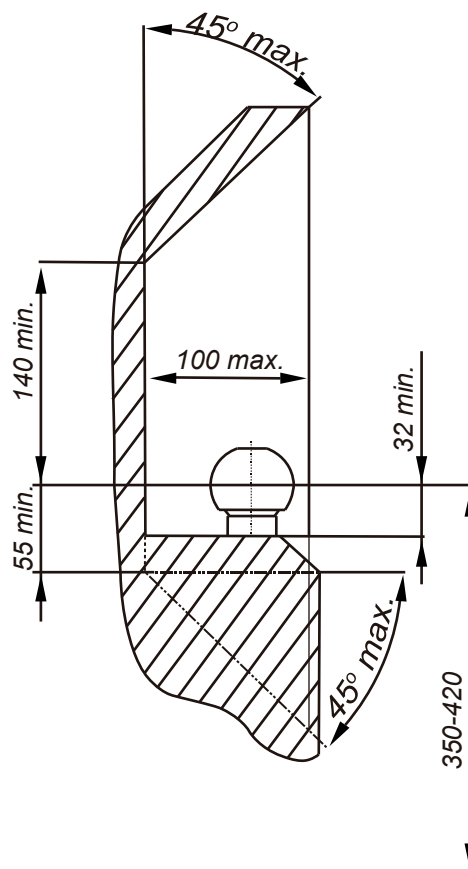

PL Należy zagwarantować przestrzeń swobodną według załącznika VII, rysunek 25a/b Regulaminu EKG ONZ 55.01 przy dopuszczalnym ciężarze całkowitym pojazdu.

F L'espace libre doit être garanti conformément à l'annexe VII, illustration de la réglementation 55.01 CE pour un poids total en charge autorisé du véhicule.

GB The clearance specified in appendix VII, diagram 25a/b of Regulation No. 55.01 UN EU must be guaranteed at laden weight of the vehicle.

D Der Freiraum nach Anhang VII, Abbildung 25a/b der Vorschriften 55.01 EG ist zu gewährleisten bei zulässigem Gesamtgewicht des Fahrzeuges.

Moment skręcący dla śrub i nakrętek (8.8) Torgue settings for nuts and bolts (8.8)	
M8	25Nm
M10	55Nm
M12	85Nm
M14	135Nm
M16	195Nm

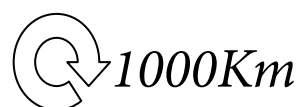

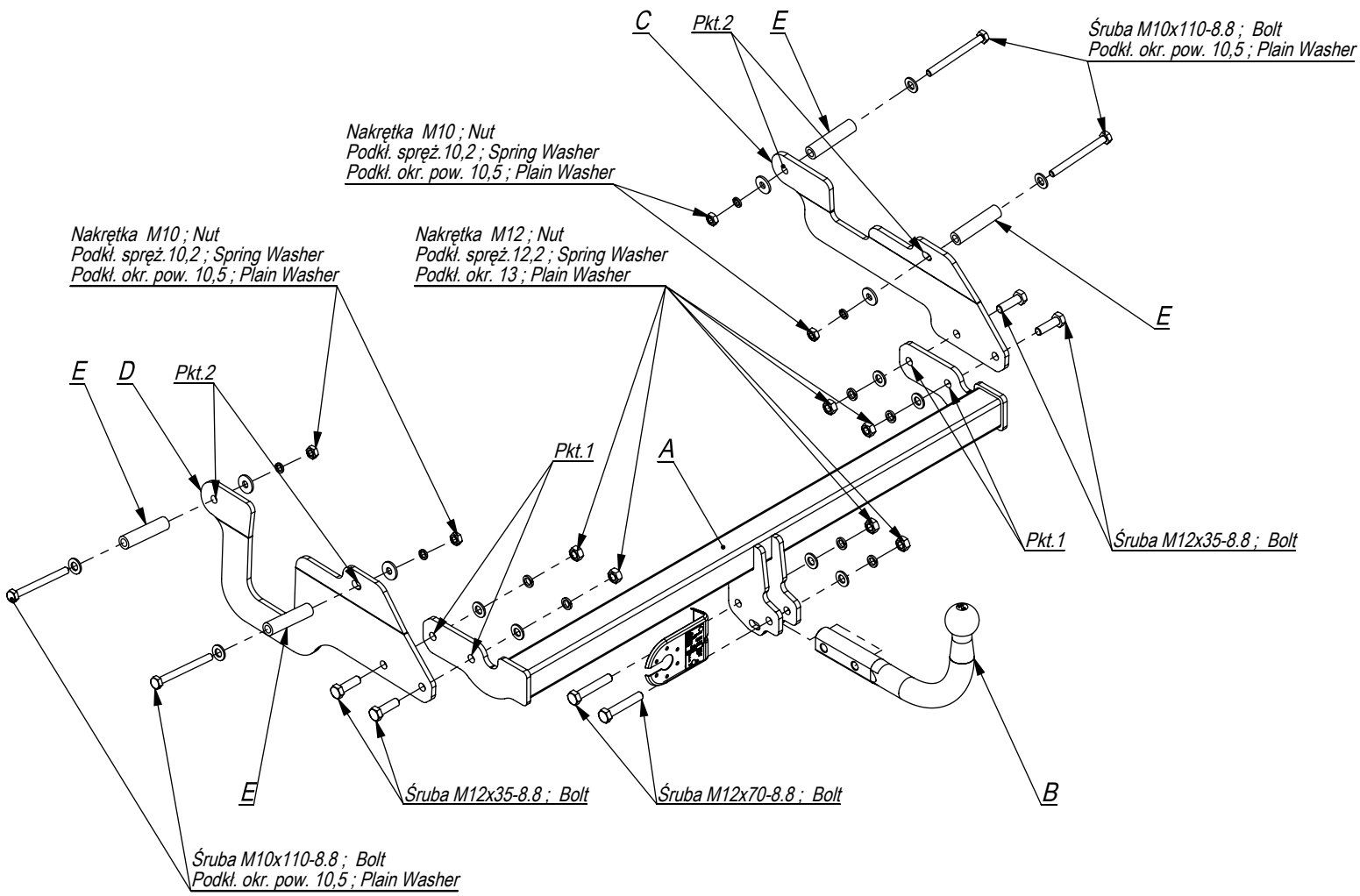

	A	x1		M12x70	2
				M12x35	4
				M10x110	4
	C	x1		M12	6
				M10	4
	E	x4		Ø30xØ10,5x3	8
				13	6
	G	x1		10,5	4
				12,2	6
				10,2	4

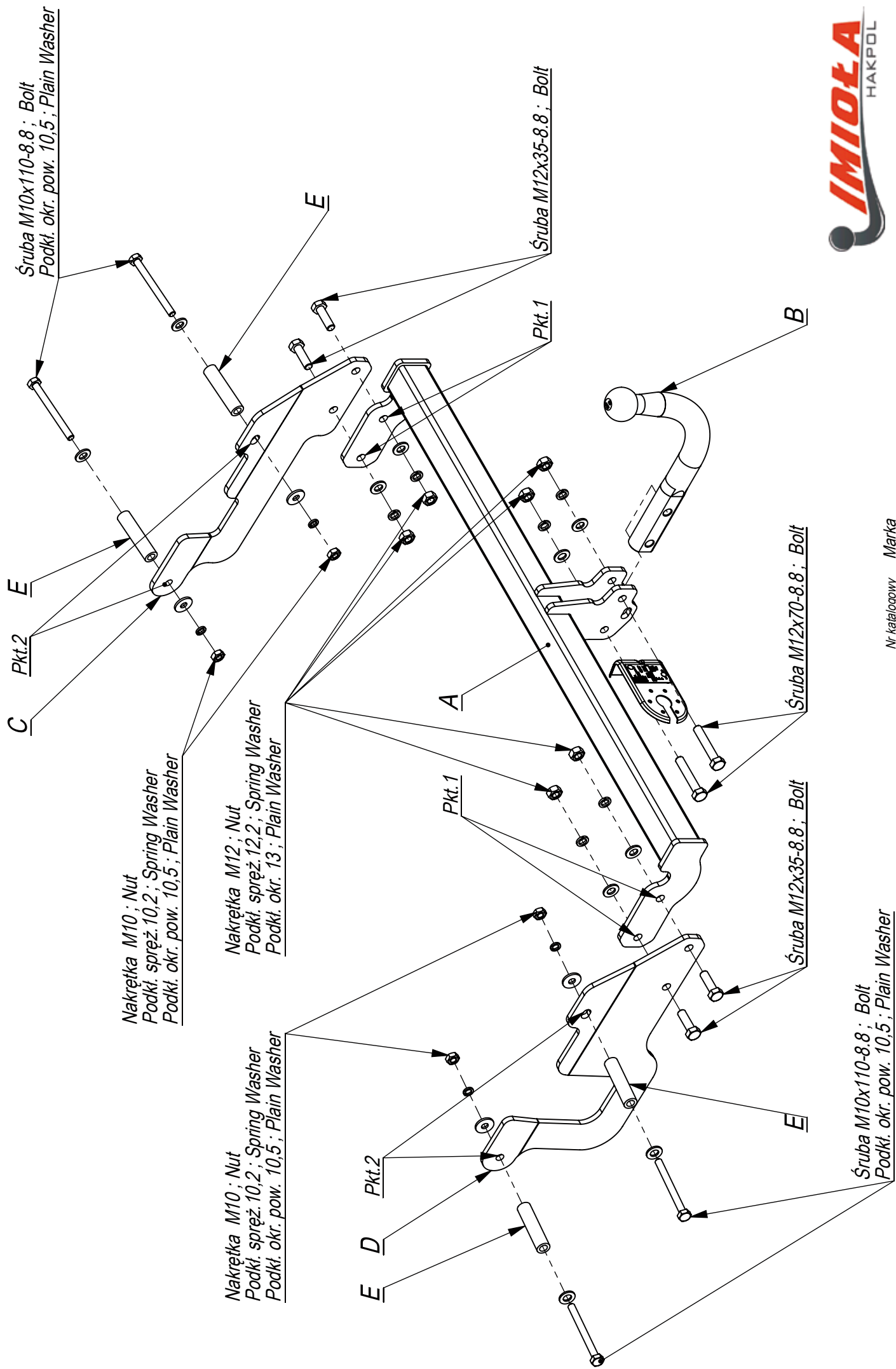

- Zdjąć koło zapasowe.
- Zdemontować osłonę termiczną.
- Udrożnić otwory technologiczne w podłużnicach i przykręcić elementy C i D śrubami M10x110 8.8 (pkt 2) stosując tulejki E.
- Belkę haka A przykręcić śrubami M12x35 8.8 (pkt 1).
- Przykręcić i dopasować osłonę termiczną.
- Zamontować koło zapasowe.
- Dokręcić wszystkie śruby z momentem według tabeli.
- Dokręcić kulę i blachę gniazda elektrycznego.
- Podłączyć instalację elektryczną.

- Insert the distance sleeves in the technological holes, in the metal clamps.
- Screw the elements C , D to the metal clamps with bolts M10x110 8.8 (point 2).
- Screw the main bar A to the elements C with bolts M12x35 8.8 (point 1).
- Tighten all the bolts according to the torque setting- see the table.
- Fix the ball and electric plate.
- Connect the electric wires.

- Placer les douilles d'écartement dans les ouvertures de longerons,
- Visser les éléments d'attache C, D aux longerons par les boulons M10x110, 8.8 (point 2),
- Visser les éléments C à la traverse d'attache A par les boulons M12x35 8.8 (point 1),
- Serrer tous les boulons avec un couple de serrage selon tableau,
- Visser le crochet d'attelage et socle de prise électrique,
- Raccorder le circuit électrique.

